

Cardioid Dynamic Wireless Microphone

WX-RP158

Operating Instructions

RAMSA



Panasonic[®]

Before attempting to connect or operate this product,
please read these instructions completely.



CAUTION

RISK OF ELECTRIC SHOCK
DO NOT OPEN



CAUTION:
TO REDUCE THE RISK OF ELECTRIC SHOCK, DO NOT REMOVE COVER (OR BACK). NO USER SERVICEABLE PARTS INSIDE.
REFER SERVICING TO QUALIFIED SERVICE PERSONNEL.



SA 1965

The lightning flash with arrowhead symbol, within an equilateral triangle, is intended to alert the user to the presence of uninsulated "dangerous voltage" within the product's enclosure that may be of sufficient magnitude to constitute a risk of electric shock to persons.



SA 1966

The exclamation point within an equilateral triangle is intended to alert the user to the presence of important operating and maintenance (servicing) instructions in the literature accompanying the appliance.

The serial number of this product may be found on the bottom of the unit.

You should note the serial number of this unit in the space provided and retain this book as a permanent record of your purchase to aid identification in the event of theft.

Model No. _____

Serial No. _____

WARNING:

TO PREVENT FIRE OR SHOCK HAZARD, DO NOT EXPOSE THIS APPLIANCE TO RAIN OR MOISTURE.

CONTENTS

PREFACE	2
FEATURES	2
PECAUTIONS	3
BATTERY INSTALLATION	4
SUGGESTIONS	5
MAJOR COMPONENTS	6
FREQUENCY SETTING	7
TRANSMITTING CHANNEL AND FREQUENCY	9
SPECIFICATIONS	10
STANDARD ACCESSORIES	11
DIRECTIONAL CHARACTERISTICS	11
FREQUENCY RESPONSE	11

READ THE FOLLOWING INSTRUCTIONS BEFORE USE

Use of the Panasonic Wireless devices is regulated by the Federal Communications Commission as described in Part 74 subpart H of the FCC regulations, and users authorized there by are required to obtain an appropriate license.

CAUTION:

It is a violation of Federal Law to begin operating this system prior to obtaining an FCC Radio License. The FCC ID number for this radio equipment is listed below.

FCC ID : ACK9TAWX-RP158

PREFACE

The Cardioid Dynamic Wireless Microphone WX-RP158 is designed to be used with the Diversity Receivers WX-RP810/WX-RP820 with wireless antenna WX-RP921.

The six wireless microphone can be used as a system. Furthermore, the Cardioid Dynamic Wireless Microphone WX-RP158 can be used with ENG Wireless Receiver WX-RP700 for ENG purpose.

Reliable, time proven, LSI technology makes it possible to achieve the compact size and low weight that enhances mobility.

A PLL synthesizer system provides stable transmission throughout the production area, and an on board compander system helps.

FEATURES

- The freedom of movement is now achieved by the simple operation of the new PLL wireless transmitter.
- The PLL synthesized oscillator makes it simple to change the transmission frequency to insure interference-free operation anywhere.
- The space diversity reception is least susceptible to multipath reflection dropouts.
- The battery charge condition is indicated by the Battery Status Indicator.
- Superb audio quality.
- Possible to cover the 49 usable channels solely by this model.
- It goes anywhere with "Wireless Transmitter System".
- The PAD switch makes easy set-up for sound input and battery status indicator shows battery condition.
- A maximum of 6 microphones can be used in the same area.

PRECAUTIONS

- Do not expose the wireless microphone to water or moisture.
 - Do not operate the wireless microphone if it becomes wet. Do take immediate action if the transmitter does become wet. Turn power off and consult with qualified service personnel. Moisture can damage the transmitter and also create the danger of electric shock.
 - Do not use the wireless microphone beyond its temperature, humidity or power source range.
 - (a) Ambient temperature range must not exceed 32°F - 104°F (0°C - +40°C).
 - (b) Avoid using the wireless microphone when humidity is above 90%.
 - For cleaning the body case, wipe with dry cloth. If necessary, use a damp cloth with mild detergent. Do not use chemicals such as benzine, alcohol or thinner for cleaning.
 - If intermittent audio sound occurs during operation, turn off the power and consult with qualified service personnel.
 - Do not subject the microphone to shock.
- Do not use this wireless microphone in places affected by strong electrical or magnetic fields, such as near AC power lines, motors, transformers or generators.

When operating the wireless system under these conditions, the wireless microphone and antennas should be between 6.7ft (2m) and 33ft (10m) apart from each other to avoid interference.
 - Do place the wireless microphone at least 6.56ft(2m) apart from the wireless antenna when more than one wireless microphone is used in different frequencies to minimize interference.
 - Before replacing the battery for wireless microphone, turn down the faders of the mixer or any other equipment which is connected to the LINE OUTPUT of diversity receiver. Otherwise noise will be generated by the battery replacing of the wireless microphone.

BATTERY INSTALLATION

Caution : when insert the battery, wireless microphone will change to operating condition. Therefore, Before inserting the battery, turn down the faders of the mixer or any other equipment.

Remove the battery if the wireless microphone is not to be used for an extended period of time.

1. Remove the battery cover by rotating it to counter-clockwise and insert the battery.
2. Replace the battery cover by rotating it to clockwise.

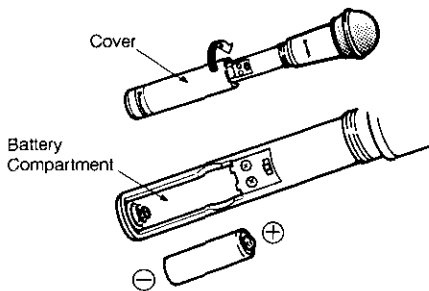

Note :

1. Confirm correct polarity of the battery. Improper battery installation can damage the unit.
2. Remove the battery if the wireless microphone is not to be used for an extended period of time.
3. Do not recharge the dry battery. The dry battery is not rechargeable.
4. Do not make a short circuit between + and - polarities of the battery.

SUGGESTIONS

Microphone position

Place the microphone between 2"(5cm) and 4"(10cm) apart from the mouth for clear sound.

Feedback(Howling)

If this unit is used in a small room with the loud-speaker, and is close to the speaker, feedback may occur.

To eliminate the feedback, turn down the volume control of your loud-speaker or change the position of the microphone.

Factors such as speaker position and room structure affect feedback. Feedback is most likely to occur when the microphone directly faces the speaker. So it is advisable to speaker position accordingly.

Noise-free sound

This unit will typically transmit over a range of approximately 100ft (30m). When the noise is occurred, observe the following points.

- The distance between the wireless microphone and the wireless antenna should be between 6.7ft (2m) to 33.3ft (10m). Do not place the wireless microphone less than 6.7ft (2m) apart from wireless antenna. Otherwise interference noise will occur.
- The wireless antenna should be far as possible from the window and any other devices which generate electrical noise, such as fluorescent lights and electric motors.

Microphones

- Place the wireless microphones at least 1.6ft (50cm) apart from each other.
- When using two wireless microphones, each must be of a different transmission frequency. Do not use 2 wireless microphones with the same transmission frequency simultaneously.

MAJOR COMPONENTS

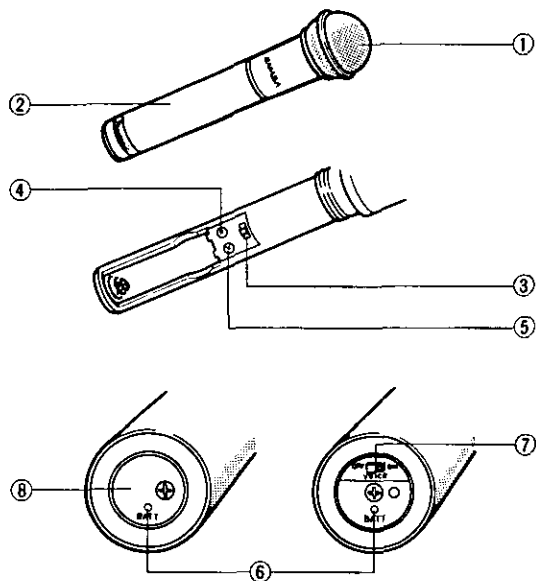

1. Windscreen

2. Grip

3. PAD Selection Switch (PAD-12/-6/0dB)

Set the PAD selection switch according to input sound.

Normally set at -6dB position at factory. Change to the 0dB position for interview or speech, and change to the -12dB position for over input.

PAD Selection Switch Position	Maximum Input Level(SPL)
0dB	130dB SPL
-6dB	136dB SPL
-12dB	142dB SPL

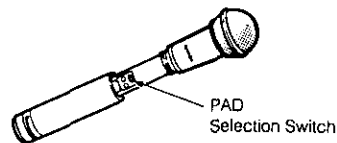

4. Group Selection Switch(G)

Refer to Page 7.

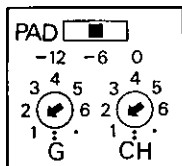

5. Channel selection Switch(CH)

Refer to Page 7.

6. Battery Indicator(BATT)

Battery Indicator shows battery condition as follows.

Green: Battery is full or enough to operate the microphone.

Red : Need the battery replacement.

Off : Replace the battery with new one.

7. Voice On/Off Switch(VOICE ON/OFF)

Always set this switch to ON position.

8. Cap

FREQUENCY SETTING

Group Description

The channel frequencies available for transmission are arranged into groups. The channels within a group are at non-adjacent frequencies. This reduces the likelihood of interference between transmitters when multiple WX-RP158's are used in close proximity. Therefore, one group should always be selected when using more than one transmitter/receiver system. Each system may then be set to a different channel within that group.

- Groups 1, 2, 4 and 5 each consist of 6 channels.
- Groups 3 and 6 each consist of 5 channels.
- If suitable channels cannot be found in Groups 1 - 6, use the groups designated • and : .
- More than one group may be used if necessary, but be sure to confirm beforehand that there is no adjacent-channel interference between transmitters.

Note:

1. Be sure to use this wireless microphone and the diversity receiver at the same frequency.
2. Diversity receivers which are used in the same area should be set to the same group number and

each channel selection switch set to a different number.

3. In case that radio interference is encountered, change the frequency immediately.
4. The distance between groups may be changed by various conditions.

How to set the frequency

1. Turn off the power of receiver.
2. set the group selection switch of this wireless microphone to the same number as the one of the tuner unit of diversity receiver.
3. Set the channel selection switch of this wireless microphone to the same number as the one of the tuner unit of diversity receiver.

Note: Use the Miniature screw driver to set the above switches.

4. Turn on the power of diversity receiver side only. Set the diversity receiver to the desired frequency. Confirm that the receiving indicator on the receiver lights off.

Note:

If the receiving level indicator lights with turning on the power of the diversity receiver and turning off the power(remove the battery from wireless microphone) of wireless microphone, this diversity receiver will be interfered by the external radio wave.

Do not set the wireless microphone to out of transmission frequency before batter installation.

Otherwise Battery indicator will not lights up.

However, battery will consume even above condition.

TRANSMITTING CHANNEL AND FREQUENCY

Broadcasting system description and cautions for UHF Interference

This microphone works with FM modulated signals in the UHF frequency range of 797.000 MHz to 803.000 MHz.

Television channels 68 and 69 also fall within this range. Check the local area for these TV stations. Then select groups as follows.

Channel 68 broadcast area: To use Groups 4, 5, 6 or :

Channel 69 broadcast area: To use Groups 1, 2, 3 or ·

Note: In areas which receive both channels 68 or 69, choose the group with least interference. However, be sure to especially avoid using the following channels which are on the exact same broadcast frequencies:

GROUP 2/CHANNEL 6 (CH68)

GROUP :/CHANNEL 3 (CH69)

Frequency List 1 (CH68)

Carrier frequency (MHz)	GROUP • CHANNEL							
	GROUP1	GROUP2	GROUP3	GROUP4	GROUP5	GROUP6	GROUP•	GROUP:
797.000	CHANNEL 1							
797.125		CHANNEL 1						
797.250	CHANNEL 2							
797.375		CHANNEL 2						
797.500			CHANNEL 1					
797.625							CHANNEL 1	
798.750	CHANNEL 3							
798.000			CHANNEL 2					
798.125							CHANNEL 2	
798.250			CHANNEL 3					
798.375							CHANNEL 3	
798.500		CHANNEL 4						
798.625	CHANNEL 4							
798.750							CHANNEL 4	
798.875							CHANNEL 5	
799.000	CHANNEL 5							
799.125							CHANNEL 6	
799.250			CHANNEL 4					
799.375		CHANNEL 5						
799.500							CHANNEL •	
799.625	CHANNEL 6							
799.750		CHANNEL 6						
799.875			CHANNEL 5					

STANDARD ACCESSORIES

Microphone Adaptor(5/8-27)	1 pc
Screw Adaptor(5/8-27 - 3/8-27)	1 pc
Miniature Screw Driver.....	1 pc
Label for channel selection.....	1 set
Soft Case.	1 pc

DIRECTIONAL CHARACTERISTICS

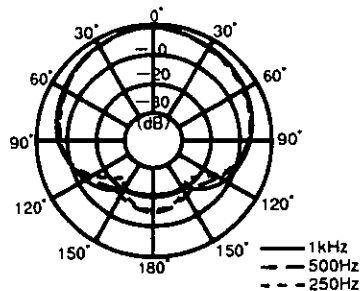

FREQUENCY RESPONSE

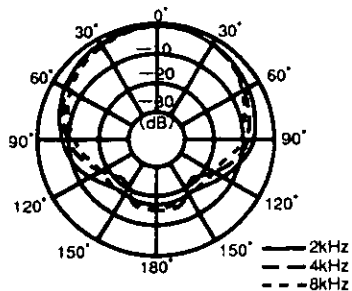
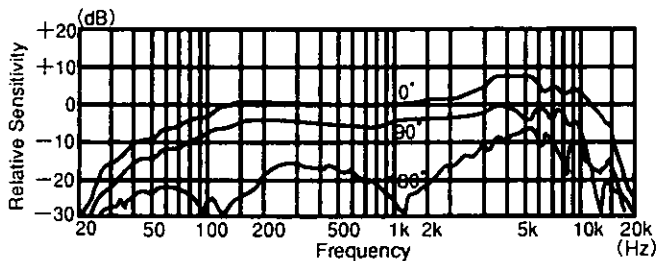

Panasonic

Broadcast & Television Systems Company

Division of Matsushita Electric Corporation of America

RAMSA/Professional Audio Systems

Executive Office: One Panasonic Way, Secaucus, New Jersey 07094
6550 Katella Ave. Cypress, CA 90630 (714) 373-7277

N0693-0

YWA8QA3020AN

Printed in Japan

Ⓝ 22